



**Warning:** Disconnect all power sources before installing or servicing

**Warning:** All wiring of the Motor Efficiency Controller must follow National and/or local electrical code.

**Warning:** If you are unable to install the MEC according to these guidelines, contact Technical Support before proceeding.

The following guideline should be used when installing the Motor Efficiency Controller (MEC) into an existing escalator control system. This document provides guidelines and wiring diagrams for typical escalator control systems. Please contact Technical Support for more detailed information.

**Delta Motors**

1. Connect the MEC, between the Circuit Breaker and Up and Down Contactors.
2. Connect Input 1 on the MEC in parallel with the coil of the Run Contactor.
3. Connect Output 1 on the MEC in series with the auxiliary contracts on the Run Contactor or Run Circuit. Output 1 will be closed when the motor is running
4. Connect Output 2 on the MEC in series with the overload and Safety Chain. Output 2 will open if the MEC Faults.
5. Set DIP Switch 7 to "ON" and all DIP Switches to the "OFF" position and the FLC pot to the FLA of the motor.
6. Any device such as a brake, transformer, etc. that requires line voltage for its source needs to be connected at the line side of the MEC. Connection at the load side can cause devices to not operate properly due to reduced voltage generated by MEC while in energy savings mode.

**Typical Wiring Diagram for Delta Motors**

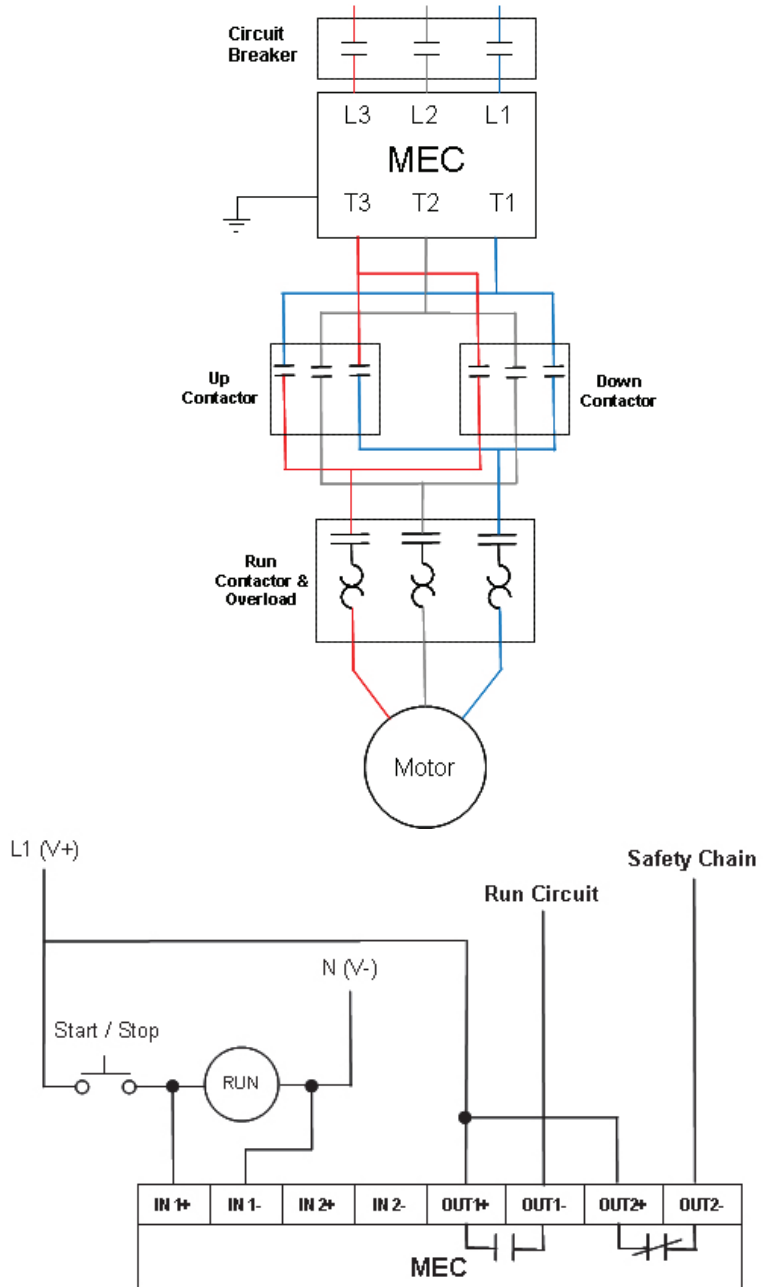

**Wye-Delta Motors**

1. It is recommended that the Wye start be disabled in the control system, when possible. If the Wye start can be disabled, then the system should be wired according to the guidelines on the previous page.
2. Connect the MEC, between the Circuit Breaker and Up and Down Contactors.
3. Connect Input 1 on the MEC in series with the normally open auxiliary contacts of the Wye and Delta Contactors. The Wye and Delta auxiliary contacts must be wired in parallel since the Wye auxiliary contact will only be closed during initial startup and the Delta auxiliary contact will close after the Wye contactor is de-energized.
4. Connect Output 1 on the MEC in series with the auxiliary contacts on the Delta Contactor or Run Circuit. Output 1 will be closed when the motor is running.
5. Connect Output 2 on the the MEC in series with the overload and Safety Chain. Output 2 will open if the MEC Faults.
6. Set DIP Switches 7 and 8 "ON" and all other DIP Switches to the "OFF" position. Set the FLC pot to the FLA of the motor.
7. Any device such as a brake, transformer, etc. that requires line voltage for its source needs to be connected at the line side of the MEC. Connection at the load side can cause devices to not operate properly due to reduced voltage generated by the MEC while operating.

**Typical Wiring Diagram for Wye-Delta Motors**

